

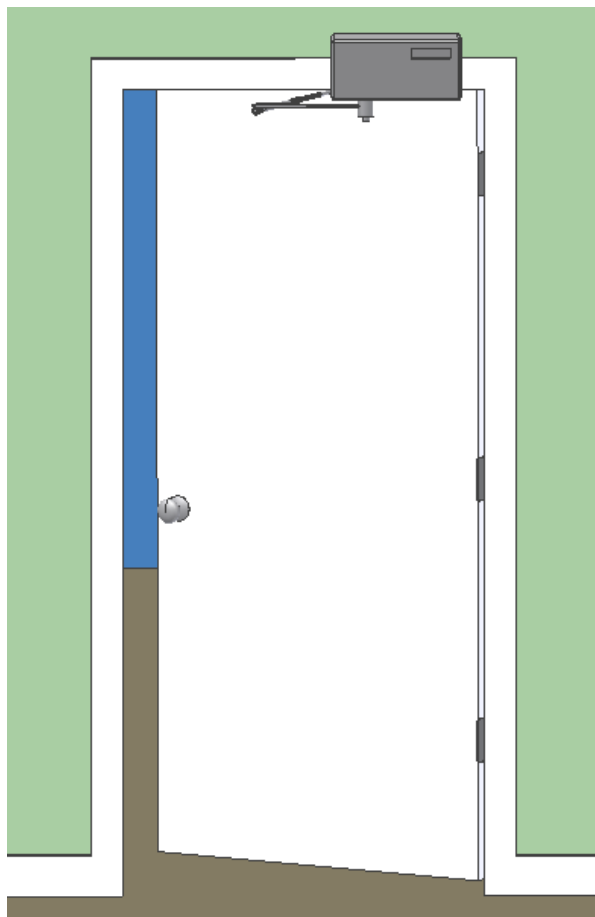

## Model 2300JR Installation Guide



**POWER ACCESS CORPORATION**  
**4 HERSHEY DRIVE, DOCK 4**  
**ANSONIA, CT 06401**  
**800-344-0088**

**WEBSITE:** [www.power-access.com](http://www.power-access.com)  
**EMAIL:** [salesinfo@power-access.com](mailto:salesinfo@power-access.com)

# MODEL 2300JR PARTS LIST

## STANDARD PARTS

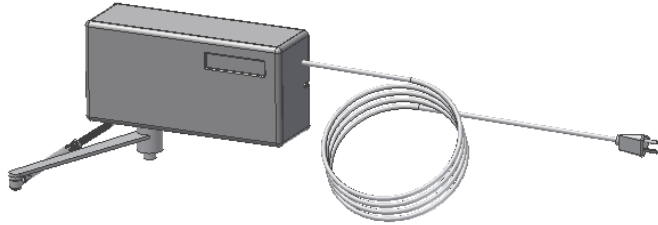

### MODEL 2300JR (MOTOR UNIT)

**DIMENSIONS: 12 3/4" W x 6" H x 3 1/2" D**

WITH SLIP FRICTION CLUTCH ARM,  
ADJUSTABLE FOREARM AND SHOE, 9 FOOT 115VAC  
POWER CORD, AND 300MHz RADIO RECEIVER

**WARNING: DO NOT HANDLE MODEL 2300JR BY POWER CORD**



### DONUT MAGNET (PART NUMBER 2440)

SEE PAGE 7, ITEM 4.1.6 AND PAGE 14



### (6) #10 1-1/2" WOOD SCREWS

(4) – FOR ATTACHING MOTOR UNIT TO DOOR

(2) – FOR ATTACHING ARM SHOE TO JAMB



### (4) BINDING BOLTS

FOR ATTACHING UNIT TO DOOR WITH THROUGH HOLES IN DOOR.  
(THESE ARE USED IN PLACE OF THE WOOD SCREWS)

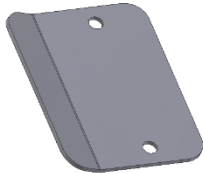

### BLANK LATCH PLATE

USED IN PLACE OF ELECTRIC STRIKE



### DOOR STOP

MOUNTED ON DOOR HINGE

SEE PAGE 5

# MODEL 2300JR PARTS LIST

## OPTIONAL ACCESSORIES

### ELECTRIC STRIKE

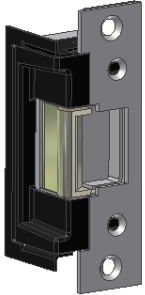

**MODEL 4560S-24VDC ELECTRIC STRIKE AND OPTION 791 FACE PLATE**  
INSTALLATION AND WIRING INSTRUCTIONS INCLUDED SEPARATELY

### WIRELESS REMOTE TRANSMITTERS



**MODEL 4495SQ**  
**WALL MOUNTED**  
**4.5" SQUARE PUSH PLATE**



**MODEL 4437S**  
**WIRELESS PROGRAMMABLE**  
**KEYLESS ENTRY SYSTEM**

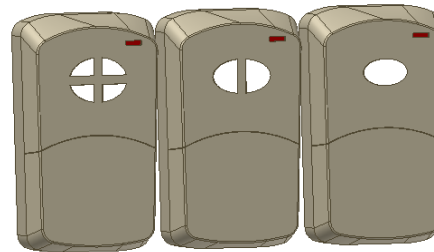

**GARAGE DOOR STYLE TRASMITTER**  
**MODEL 4440T – SINGLE CHANNEL**  
**MODEL 4440D – TWO CHANNEL**  
**MODEL 4440DD – FOUR CHANNEL**



**PENDANT STYLE**  
**TRANSMITTER**  
**MODEL 4440TK –**  
**SINGLE CHANNEL;**  
**MODEL 4440TKD –**  
**TWO CHANNEL**

# 1. PRECAUTIONS AND REQUIREMENTS

## 1.1 PRECAUTIONS:

- 1.1.1 THE MODEL 2300JR IS NOT SUITABLE FOR DOORS THAT OPEN TO THE EXTERIOR SUBJECT TO WINDY CONDITIONS. WIND WILL CAUSE THE MODEL 2300JR TO OPERATE IMPROPERLY.
- 1.1.2 VERIFY THAT YOU HAVE THE CORRECT MODEL NUMBER FOR YOUR APPLICATION. REFERENCE **MODEL CONFIGURATIONS** (PAGE 20) TO VERIFY YOU HAVE THE CORRECT UNIT. IF NOT, SEE **CHANGING HAND DIRECTION** (PAGE 15, 9.1).
- 1.1.3 THE DOOR THAT THE MODEL 2300JR IS TO BE MOUNTED TO SHOULD BE PLUMB, SQUARE, AND NOT WARPED. THE DOOR SHOULD NOT STICK TO THE JAMB.
- 1.1.4 THE DOOR THAT THE MODEL 2300JR UNIT IS TO BE MOUNTED TO SHOULD HAVE STANDARD BUTT HINGES, VOID OF ANY SPRINGS. NO OTHER DOOR OPEN OR CLOSE ASSIST FEATURES SHOULD BE ATTACHED TO THE DOOR. 20 LBS. OF INITIAL FORCE IS APPLIED AT THE LEADING EDGE OF THE DOOR TO BEGIN THE OPENING AND CLOSING ACTIONS. FLIMSY OR IMPROPERLY INSTALLED HINGES MAY PREVENT THE DOOR OPENER FROM OPERATING PROPERLY.

## 1.2 POWER REQUIREMENTS:

THIS MODEL IS SUPPLIED WITH A 9 FOOT POWER CORD THAT PLUGS INTO A 115V AC OUTLET. WHEN THE OPTIONAL ELECTRIC STRIKE IS PROVIDED, IT IS SUPPLIED WITH 12 FEET OF LOW VOLTAGE WIRE TO CONNECT THE ELECTRIC STRIKE PLATE TO THE STRIKE TERMINALS ON THE MAIN CIRCUIT BOARD (SEE PAGES 10 AND 16). THE TERMINALS ARE UNIVERSAL.

**WARNING: USE CAUTION AND DISCONNECT POWER WHEN WIRING ELECTRIC STRIKE.**

## 1.3 CLEARANCE REQUIREMENTS:

AT LEAST 6" OF CLEARANCE ABOVE THE TOP OF THE DOOR IS NEEDED.

**WARNING: THE MODEL 2300JR MUST NOT OPEN PAST 90 DEGREES.**

6" MINIMUM  
CLEARANCE FROM  
TOP EDGE OF DOOR  
TO CEILING

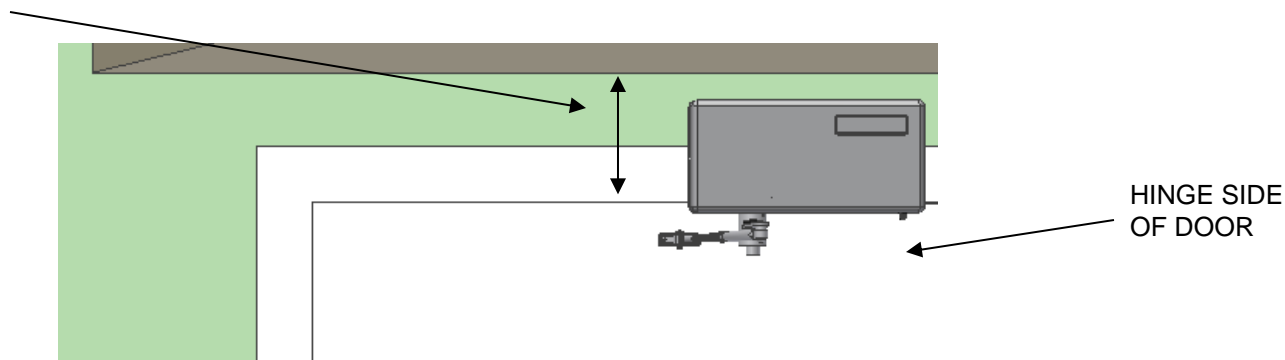

## 2. DOOR STOP

### 2.1 DOOR STOP INSTALLATION

A HARD DOOR STOP MUST BE USED TO PREVENT THE DOOR FROM TRAVELING PAST 90 DEGREES WHEN OPENING. A HINGE MOUNTED STANDARD DUTY DOOR STOP IS INCLUDED IN THE MODEL 2300JR PACKAGE. TO INSTALL THIS DOOR STOP REMOVE THE HINGE PIN FROM THE TOP DOOR HINGE. REINSERT THE PIN WITH THE DOOR STOP IN PLACE. ADJUST THE THREADED POST SO THE DOOR STOPS AT 90 DEGREES WHEN OPEN.

**NOTE:** A HEAVY DUTY DOOR STOP (NOT INCLUDED) IS RECOMMENDED FOR HEAVIER DOORS.

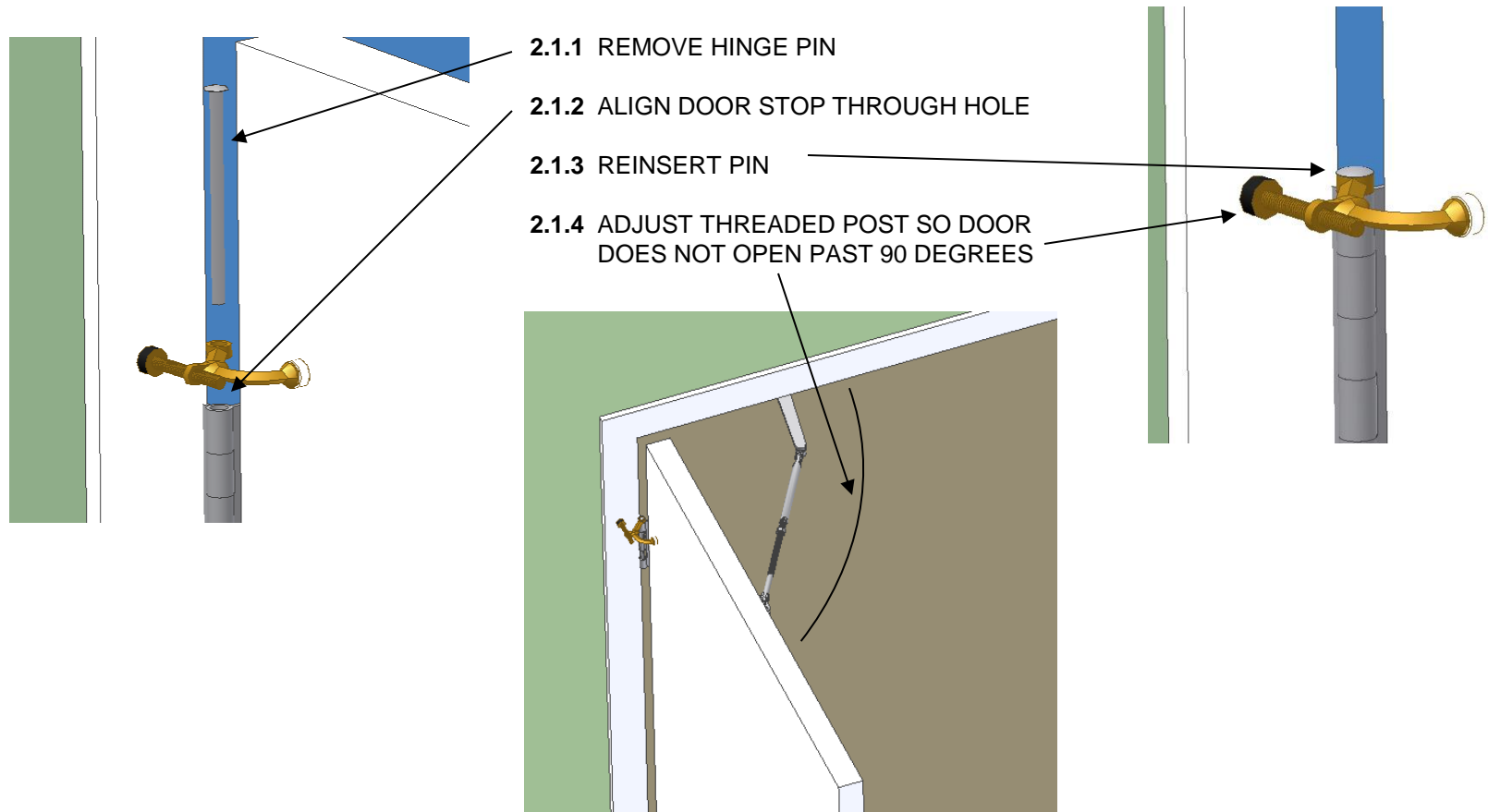

**WARNING: THE MODEL 2300JR WILL NOT OPERATE PROPERLY IF THE DOOR OPENS PAST 90 DEGREES.**

### 3. MOUNTING THE MOTOR UNIT AND LEVER ARM SHOE

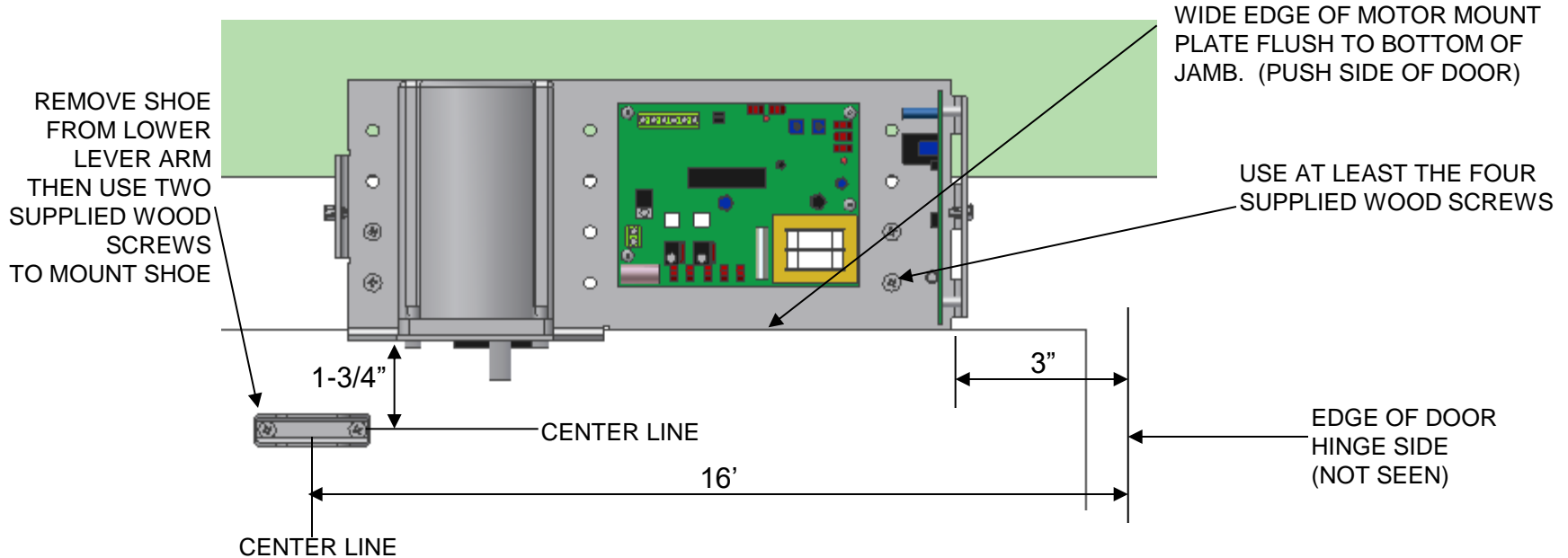

#### 3.1 MOUNTING THE MOTOR UNIT:

**WARNING: WEAR SAFETY GOOGLES PRIOR TO DRILLING.**

ALIGN THE WIDE EDGE OF THE MOTOR MOUNT PLATE FLUSH TO THE BOTTOM OF THE DOOR JAMB AND 3 INCHES FROM THE EDGE OF THE DOOR, SECURE THE MOUNT PLATE WITH AT LEAST THE 4 SUPPLIED WOOD SCREWS. ANY HOLES IN THE MOUNT PLATE MAY BE USED BUT IT IS ADVISED TO USE THE HOLES IN THE OUTERMOST ROWS TO FOLLOW BEST PRACTICE TECHNIQUE. SCREW INTO SURFACES THAT ARE FLUSH TO THE BACK SIDE OF THE MOTOR MOUNT PLATE. IT IS IMPORTANT THE SCREWS ACHIEVE A SOLID MOUNT.

#### 3.2 MOUNTING THE SHOE:

FIRST, REMOVE THE SHOE FROM THE LOWER LEVER ARM. WITH THE CENTER LINE OF THE SHOE 1-3/4 INCHES BELOW THE BOTTOM OF THE NARROW EDGE OF THE MOTOR MOUNT PLATE AND 16 INCHES FROM THE HINGE SIDE EDGE OF THE DOOR, SECURE THE SHOE TO THE DOOR WITH 2 SUPPLIED WOOD SCREWS.

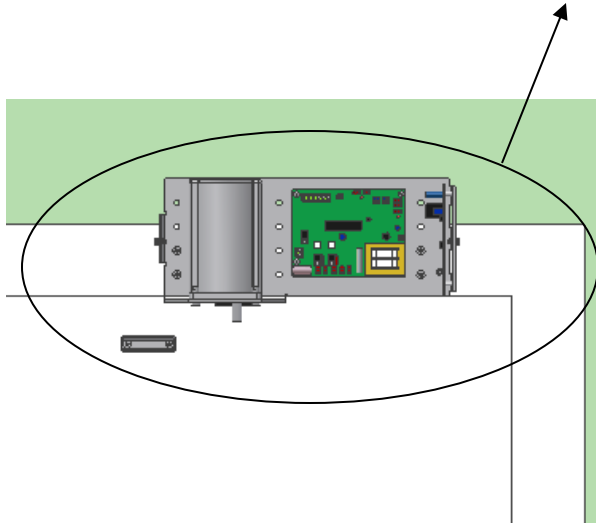

## 4. LEVER ARM ADJUSTMENT

### 4.1 ATTACHING THE ADJUSTMENT ARM TO THE SHOE:

- 4.1.1 LOOSEN NUT ON ADJUSTMENT ARM.
- 4.1.2 ADJUST LENGTH OF ADJUSTMENT ARM FOREARM SO WHEN DOOR IS SHUT AND ARM IS ENGAGED IN SHOE, THE CLUTCH ARM MAKES A 90 DEGREE ANGLE TO WALL. IF NECESSARY, REPLACE FOREARM WITH MODEL 2414 FOREARM EXTENSION SUPPLIED IN THE BOX WITH THE MODEL 2300JR.
- 4.1.3 BOLT THE ADJUSTMENT ARM IN THE CENTER HOLE OF THE SHOE BRACKET.
- 4.1.4 TIGHTEN THE ADJUSTMENT ARM NUT.
- 4.1.5 LOOSEN THE SET SCREWS IN THE CLUTCH ARM HUB. APPLY "LOCTITE BLUE" TO THE SET SCREWS AND TIGHTEN SET SCREWS IN THE CLUTCH ARM HUB.
- 4.1.6 VERIFY DONUT MAGNET IS MOUNTED TO THE SIDE OF CLUTCH ARM THAT FACES THE VELCROED SENSOR 1/8" FROM THE CLUTCH ARM HUB, CENTERED ON THE ARM. THIS TRIGGERS THE MOTOR TO SHUT OFF WHEN IN OPERATION.

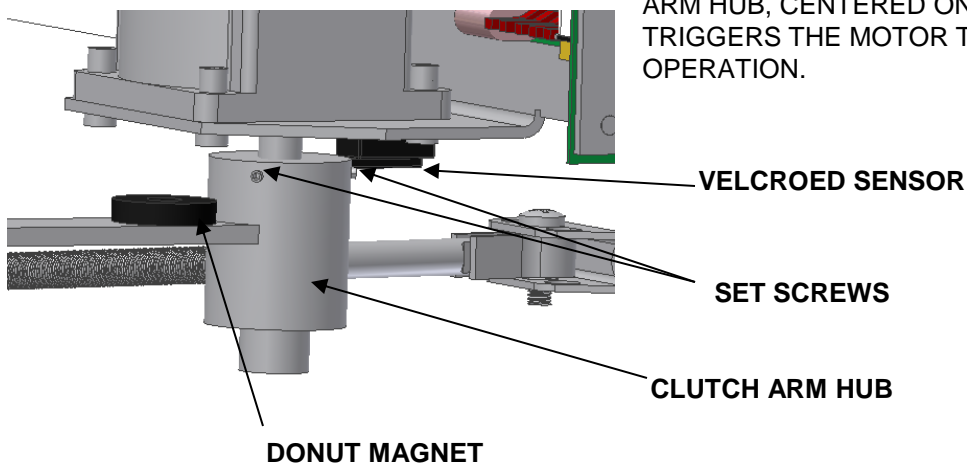
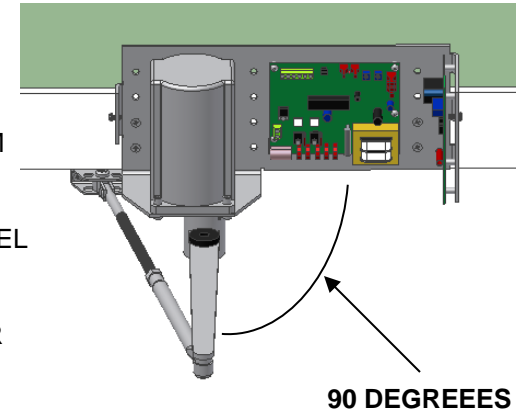
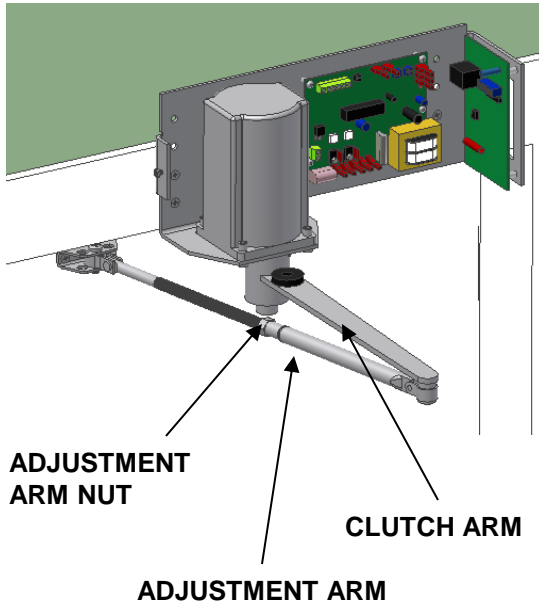

## 5. ELECTRIC STRIKE INSTALLATION

### 5.1 STRIKE INSTALLATION

THE POWER ACCESS MODEL 2300JR DOOR OPENER IS DESIGNED SO THAT THE DOOR CAN STILL BE MANUALLY OPENED WITHOUT ACTIVATING THE UNIT. THEREFORE, IT IS NECESSARY TO HAVE ANOTHER MECHANICAL FEATURE TO HOLD THE DOOR SHUT WHEN NOT IN OPERATION.

#### 5.1.1 BLANK STRIKE PLATE

IF NO MECHANICAL HOLD IS REQUIRED, THE SUPPLIED BLANK LATCH PLATE CAN BE INSTALLED IN PLACE OF THE EXISTING LATCH PLATE THAT IS CURRENTLY INSTALLED WITH THE DOOR HARDWARE.

**NOTE:** A CABINET STYLE MAGNET OR BALL DETENT (NOT SUPPLIED) MAY BE USED TO HOLD THE DOOR IN PLACE.



**BLANK LATCH PLATE**

#### 5.1.2 ELECTRIC STRIKE

POWER ACCESS MODEL 2300JR IS DESIGNED TO WORK WITH 24VDC ELECTRIC STRIKES. IF AN ELECTRIC STRIKE IS SUPPLIED, FOLLOW THE INSTRUCTIONS INCLUDED IN THE PACKAGING FROM THE ELECTRIC STRIKE MANUFACTURER TO ASSEMBLE THE STRIKE AND INSTALL IT IN THE DOOR JAMB.

**NOTE: BEFORE INSTALLATION MAKE SURE THE STRIKE IS SET TO YOUR DESIRED MODE – FAIL SAFE OR FAIL SECURE. FAIL SAFE MODE MEANS THAT IF THE STRIKE WERE TO FAIL, IT'S LATCH WILL SWING FREELY. IF IN FAIL SECURE MODE AND THE STRIKE WERE TO FAIL, THE LATCH WILL STAY LOCKED. THEREFORE A PERSON WOULD BE REQUIRED TO TURN THE DOOR KNOB TO OPEN THE DOOR. THE MODEL 4560S IS PROVIDED IN THE FAIL SECURE MODE, WHICH IS RECOMMENDED.**

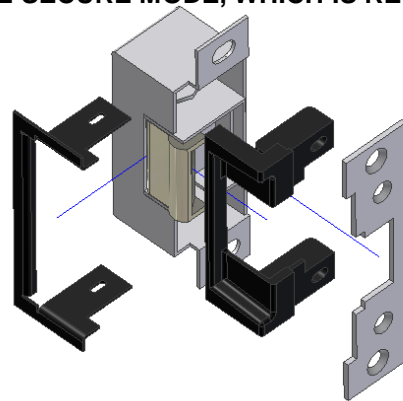

**ELECTRIC STRIKE AND FACE PLATE DISASSEMBLED  
MODEL 4560S – 24VDC SHOWN**



## 5. ELECTRIC STRIKE INSTALLATION

### 5.2 ELECTRIC STRIKE POSITIONING

WHEN INSTALLING THE ELECTRIC STRIKE AND FACE PLATE, POSITION IT IN THE DOOR FRAME, FRONT TO BACK, SO THAT WHEN THE DOOR IS CLOSED THERE IS MINIMAL GAP BETWEEN THE STRIKE PLATE LATCHING SURFACE AND THE DOOR LATCH. WHEN CLOSED, THE DOOR SHOULD HAVE LITTLE TO NO WIGGLE ROOM.

DOOR LATCH

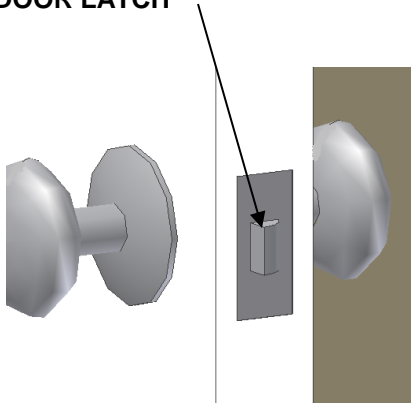

LOOSEN SCREWS TO  
ADJUST STRIKE FRONT  
TO BACK ON DOOR  
JAMB

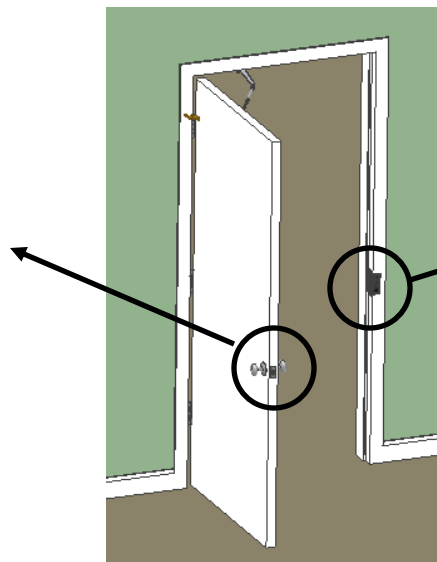

ADJUST FRONT TO BACK

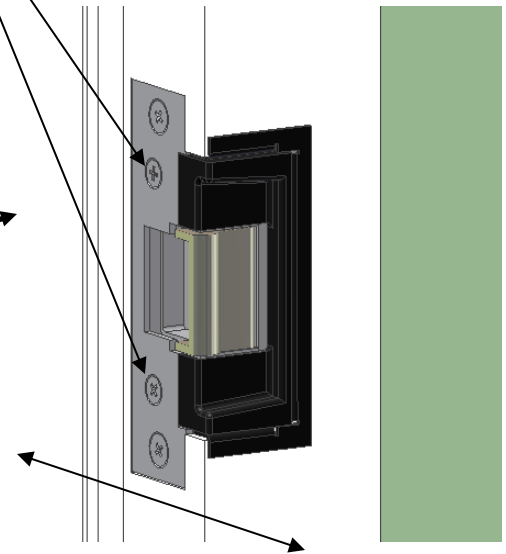

STRIKE PLATE LATCHING SURFACE. THIS IS WHAT COMES IN CONTACT WITH THE DOOR LATCH. ADDITIONAL SHIMS PROVIDED WITH THE STRIKE CAN BE USED IF THERE IS STILL TOO MUCH WIGGLE ROOM BETWEEN THE DOOR LATCH AND THE STRIKE LATCHING SURFACE.

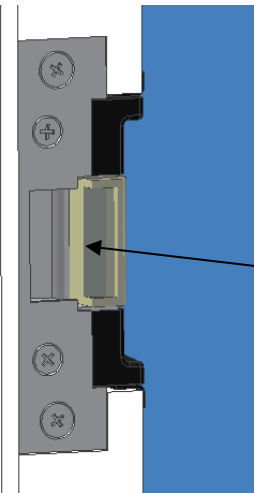

## 5. ELECTRIC STRIKE INSTALLATION

### 5.3 CONNECTING ELECTRIC STRIKE TO MODEL 2300JR

ONCE INSTALLED AND POSITIONED, USE THE TWO TWISTED 12 FOOT LOW VOLTAGE WIRES TO CONNECT TO THE TERMINALS OF THE ELECTRIC STRIKE. CAREFULLY FOLLOW "[SUPPLEMENTAL MODEL 4560S ELECTRIC STRIKE INSTALLATION GUIDE](#)" PROVIDED WITH THE MODEL 4560S ELECTRIC STRIKE. WHEN THE DOOR OPENER IS ACTIVATED IT WILL SEND A SINGLE SHOT 24VDC PULSE TO THE STRIKE TO RELEASE TENSION AND ALLOW THE DOOR TO OPEN. ONCE CONNECTED, ROUTE THE WIRES IN THE DOOR JAMB SO THEY DO NOT OBSTRUCT ANY DOOR MOVEMENT.

**WARNING: DO NOT ALLOW THE WIRES TO BECOME PINCHED OR PIERCED.**

**NOTE: THE SUPPLIED STRIKE (MODEL 4560S) HAS UNIVERSAL POLARITY. IT DOES NOT MATTER WHICH WIRE IS CONNECTED TO WHICH TERMINAL.**

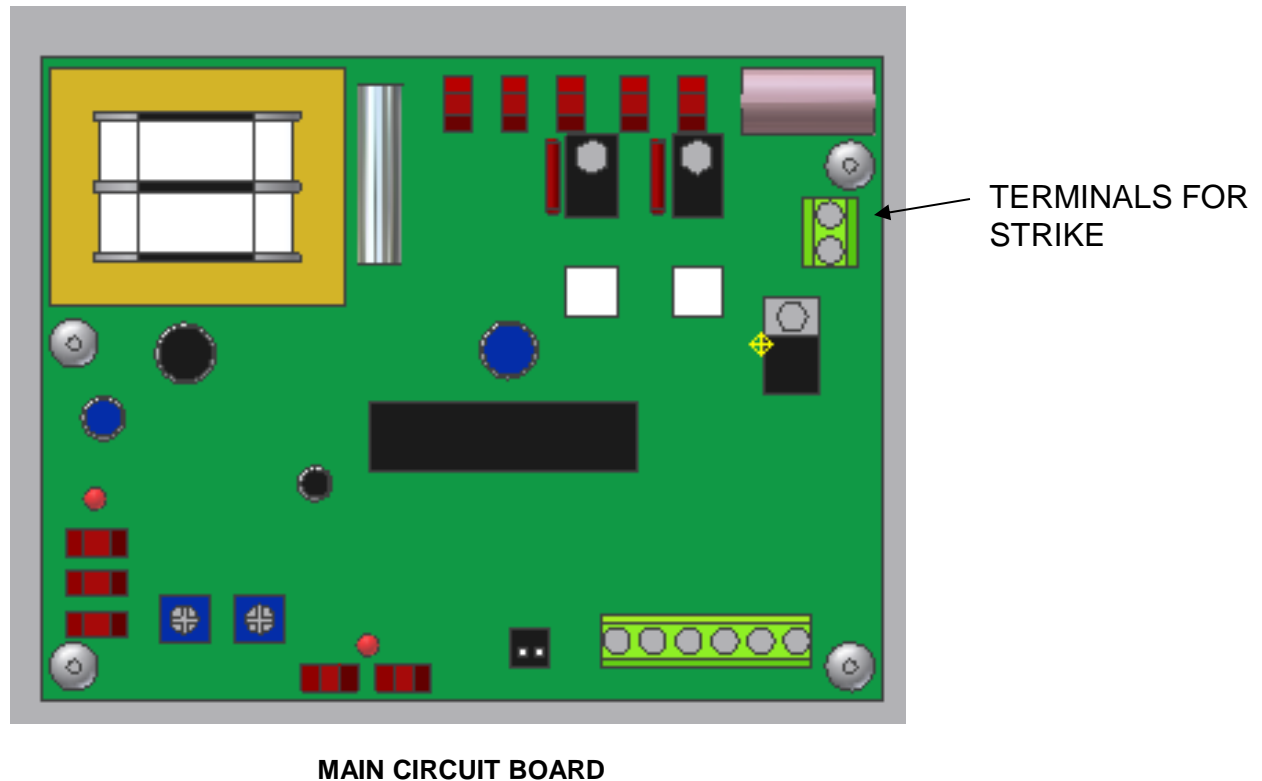

## 6. PROGRAMMING THE RECEIVER

### 6.1 RECEIVER SWITCH SETTINGS:

YOUR REMOTE TRANSMITTER AND THE RECEIVER ON THE DOOR OPENER NEED TO HAVE MATCHING DIP SWITCH CONFIGURATIONS. FOLLOW THE INSTRUCTIONS PROVIDED WITH THE REMOTE TRANSMITTER TO PROPERLY SET THE SWITCHES. (SINGLE BUTTON REMOTE SHOWN HERE BUT SAME PROCESS HOLDS TRUE FOR ANY REMOTE TRANSMITTER.)

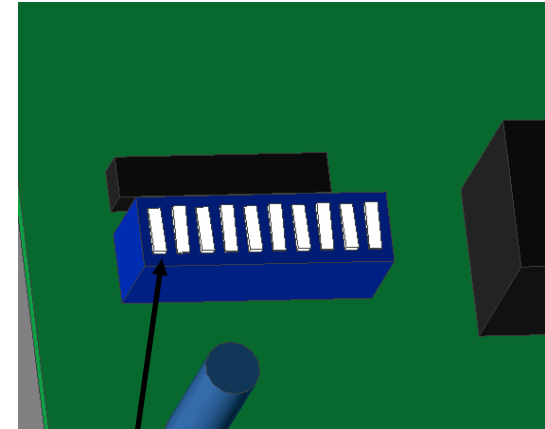
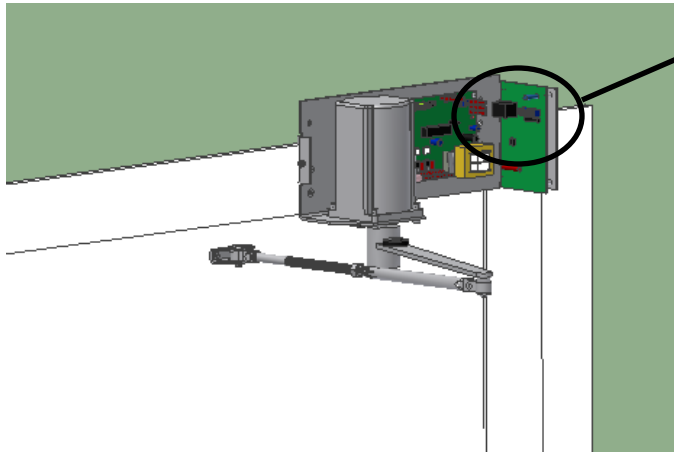

SWITCHES 1-10 ON THE MOTOR MOUNT RECEIVER NEED TO MATCH SWITCHES 1-10 ON THE TRANSMITTER.

**NOTE: OPEN = OFF**  
SOME DIP SWITCHES ARE  
LABELED ON-OFF AND SOME ARE  
LABELED OPEN-CLOSE.  
OPEN = OFF & CLOSED = ON

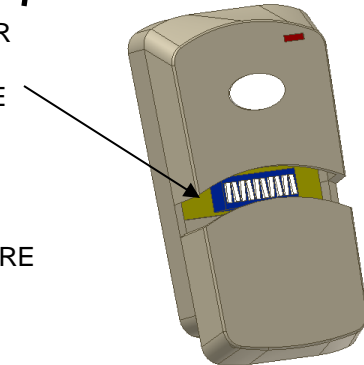

## 7. OPERATION

**CAUTION:** DO NOT ATTEMPT TO OPERATE OPENER UNTIL BOTH THE MOTOR UNIT AND LEVER ARM AND SHOE ARE SECURELY FASTENED TO THE JAMB AND DOOR. OPEN AND CLOSE THE DOOR MANUALLY A FEW TIMES TO ENSURE A FLUID MOTION OF THE LEVER ARM. THIS HELPS TO VERIFY THE MOUNTING LOCATIONS OF THE MOTOR UNIT AND SHOE.

### 7.1 OPERATION

7.1.1 PLUG THE MODEL 2300JR INTO 115V AC OUTLET.

7.1.2 ACTIVATE THE DOOR OPENER WITH A WIRELESS REMOTE TRANSMITTER. THE DOOR SHOULD OPEN SMOOTHLY TO 90 DEGREES, PAUSE, THEN CLOSE. TO ADJUST THE OPEN DWELL TIME AND/OR THE CLOSE ACTIVATION TIME REFER TO **ADJUSTMENTS** (PAGE 13). **DO NOT ALLOW THE DOOR TO OPEN PAST 90 DEGREES.**

7.1.3 REFER TO **TROUBLESHOOTING** (PAGE 19) FOR ANY ISSUES YOU ARE ENCOUNTERING.

7.1.4 AFTER ADJUSTMENTS HAVE BEEN MADE, SECURE THE MOTOR COVER OVER THE UNIT AND ROUTE THE POWER CORD SO IT DOES NOT OBSTRUCT THE MOVEMENT OF THE DOOR. POWER CORD EXITS THE HINGE SIDE.

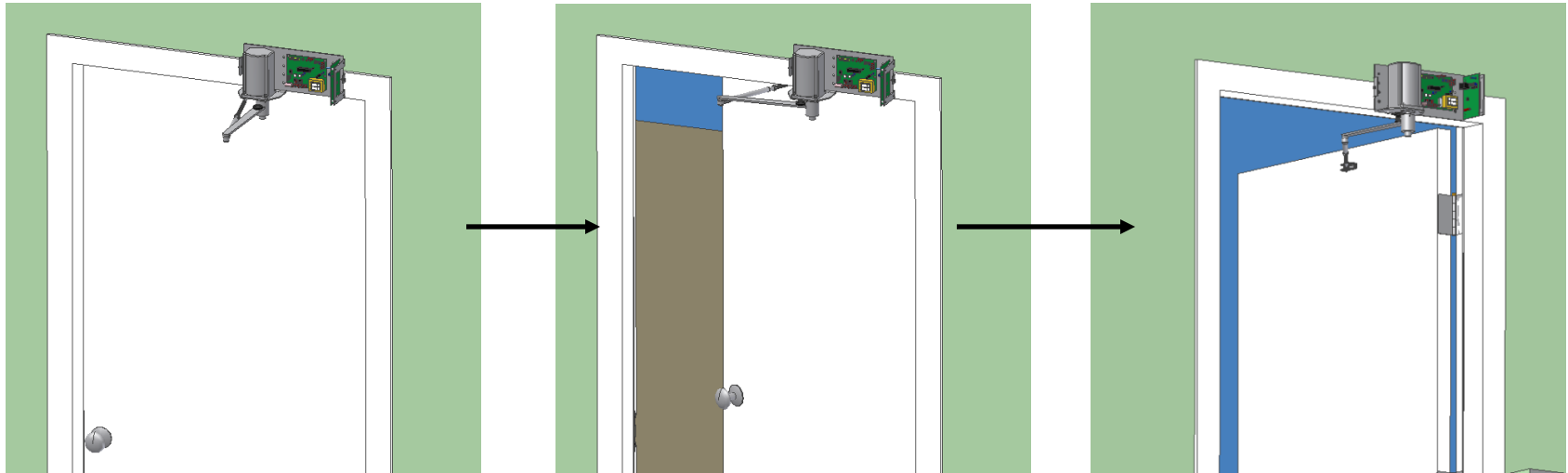

**CAUTION: DOOR SHOULD NEVER OPEN BEYOND 90 DEGREES. BEYOND 90 DEGREES THE CLUTCH ARM AND THE LEVER ARM WILL SCISSOR, CAUSING THE OPENER TO MALFUNCTION.**

## 8. ADJUSTMENTS

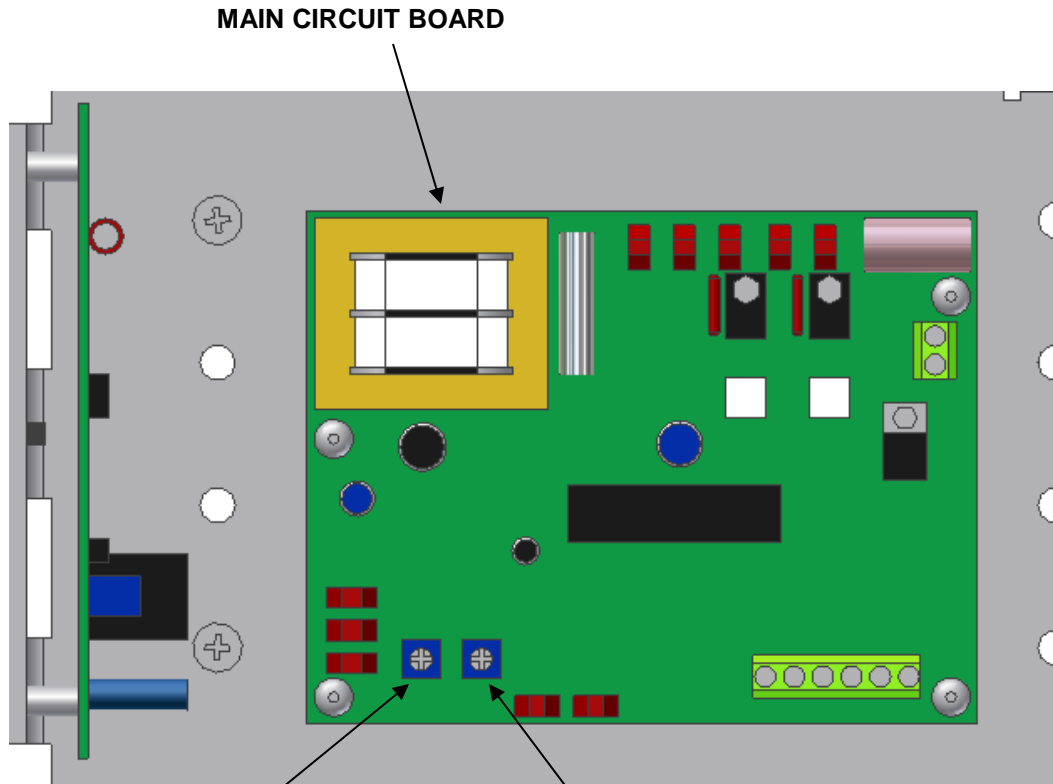

**CLOSE  
ADJ**

ROTATE CCW FOR  
REDUCED MOTOR  
ACTIVATION TIME

ROTATE CW FOR  
INCREASED MOTOR  
ACTIVATION TIME

**AUTO  
CLOSE**

ROTATE CCW TO  
DECREASE DWELL  
TIME

ROTATE CW TO  
INCREASE DWELL  
TIME

**NOTE:** MAKE  
ADJUSTMENTS BY  
SMALL FRACTIONS  
OF A TURN

### 8.1 OPEN DWELL TIME:

TO ADJUST HOW LONG THE DOOR STAYS OPEN BEFORE CLOSING, USE A SCREW DRIVER TO ADJUST "AUTO CLOSE" ON THE CONTROL BOARD. TURNING CLOCKWISE WILL INCREASE THE TIME THE DOOR STAYS OPEN. TURNING COUNTERCLOCKWISE WILL DECREASE THE DWELL TIME. THE DWELL TIME CAN BE ADJUSTED FROM 0-30 SECONDS.

### 8.2 CLOSING ACTIVATION TIME:

TO ADJUST HOW LONG THE MOTOR CONTINUES TO ROTATE WHEN CLOSING THE DOOR, USE A SCREWDRIVER TO ADJUST "CLOSE ADJ" ON THE CONTROL BOARD. IT IS RECOMMENDED THAT YOU ADJUST THIS TO HAVE THE MOTOR CONTINUE TO OPERATE FOR TWO SECONDS AFTER THE DOOR IS COMPLETELY CLOSED. THIS WILL ENSURE CONSISTENT REPEATABILITY. THE CLUTCH OF THE LEVER ARM ENSURES THAT EVEN IF THE DOOR IS SHUT OR ANY OBSTACLE IS ENCOUNTERED, THE MOTOR WILL NOT BURN ITSELF OUT. THE CLUTCH TENSION CANNOT BE ADJUSTED.

## 8. ADJUSTMENTS

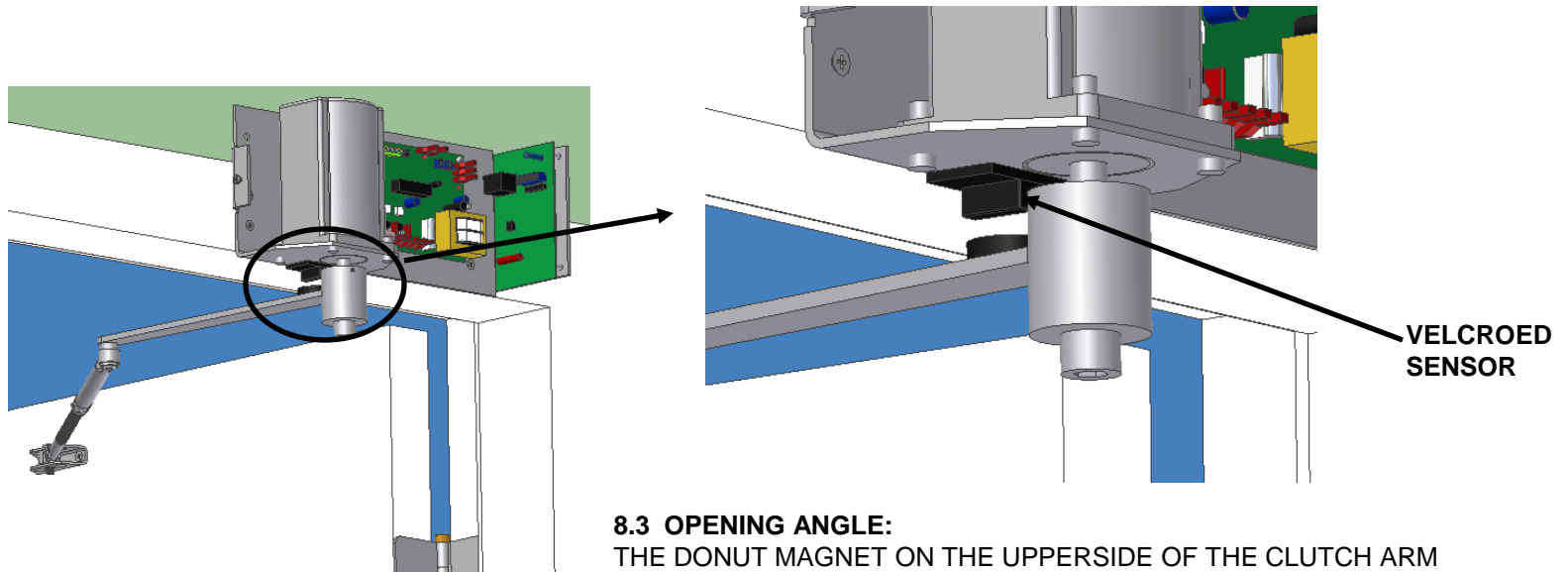

### 8.3 OPENING ANGLE:

THE DONUT MAGNET ON THE UPPERSIDE OF THE CLUTCH ARM ACTIVATES THE SENSOR VELCROED TO THE MOTOR. THE MOTOR IS TURNED OFF WHEN THE MAGNET PASSES THE SENSOR. THE DONUT MAGNET AND VELCROED SENSOR SHOULD BE POSITIONED SO THAT THE MOTOR SHUTS OFF WHEN THE DOOR IS 75-80 DEGREES OPEN AND THE DOOR WILL COAST TO A SOFT STOP AT ABOUT 90 DEGREES.

**CAUTION: A DOOR STOP MUST BE USED TO PREVENT THE DOOR FROM TRAVELING BEYOND 90 DEGREES.**

## 9. CHANGING HAND (ROTATION OF THE MOTOR)

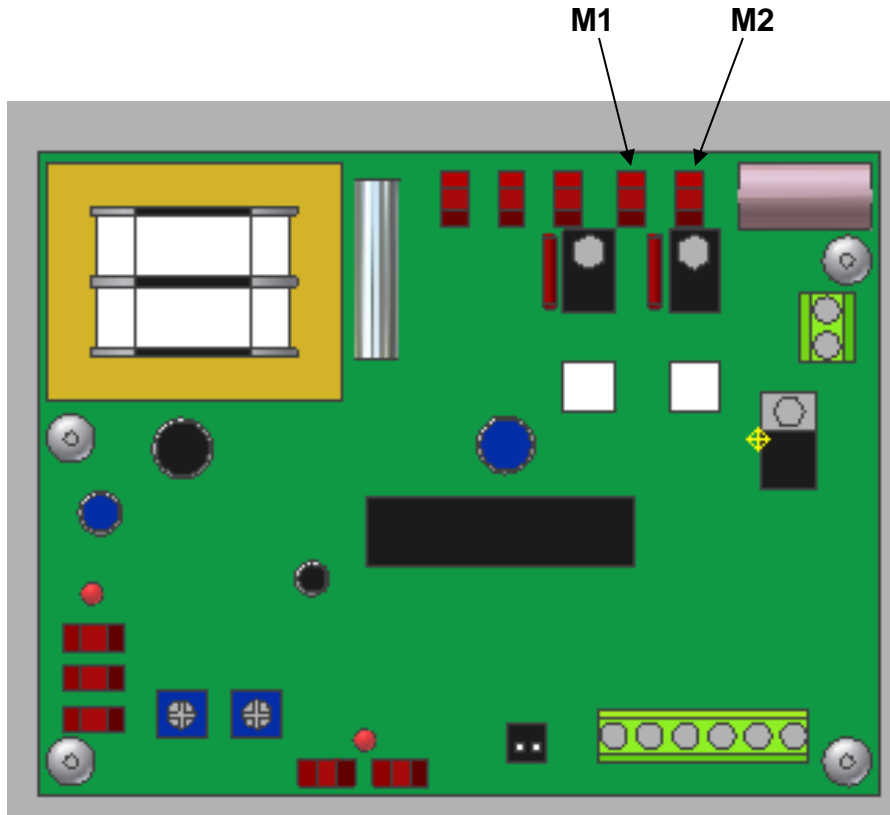

MAIN CIRCUIT BOARD

### 9.1 CHANGING HAND IN THE FIELD:

REROUTE THE POWER CORD (AND STRIKE WIRE IF APPLICABLE) SO IT EXITS THE UNIT ON THE HINGE SIDE OF DOOR.

REVERSE THE TWO MOTOR LEADS ON M1 AND M2 SO THE MOTOR WILL RUN IN THE OPPOSITE DIRECTION. TO ENSURE CORRECT POSITIONING OF THE MOTOR LEADS, PERFORM THE FOLLOWING STEPS:

1. HOLD UNIT TO NEW DOOR OR JAMB POSITION AND NOTE WHICH MOTOR LEAD (M1 OR M2) IS CLOSEST TO THE HINGE SIDE OF DOOR.
2. PLACE UNIT ON TABLE AND, IF NECESSARY, CAREFULLY REMOVE THE LEAD WIRES AND REROUTE THE BLUE WIRE TO THE MOTOR LEAD POSITION CLOSEST TO THE HINGE SIDE OF DOOR. THIS ALSO POSITIONS THE BLUE WIRE IN THE MOTOR LEAD POSITION CLOSEST TO THE MOTOR. THE BLACK WIRE THEN POSITIONS TO THE OTHER LEAD.

WHEN CONVERTING FROM JAMB MOUNT TO DOOR MOUNT, REFER TO PAGE 7 AND PERFORM THE FOLLOWING STEP:

1. REPLACE JAMB MOUNT ADJUSTMENT FOREARM EXTENSION WITH MODEL 2413 DOOR MOUNT FOREARM - CALL 800-344-0088 TO ORDER.

ONCE THE LEAD WIRES ARE CONFIRMED IN THE CORRECT POSITION, FOLLOW THE PROPER INSTALLATION GUIDE TO MOUNT THE OPENER.

# MAIN CIRCUIT BOARD FEATURE IDENTIFICATION

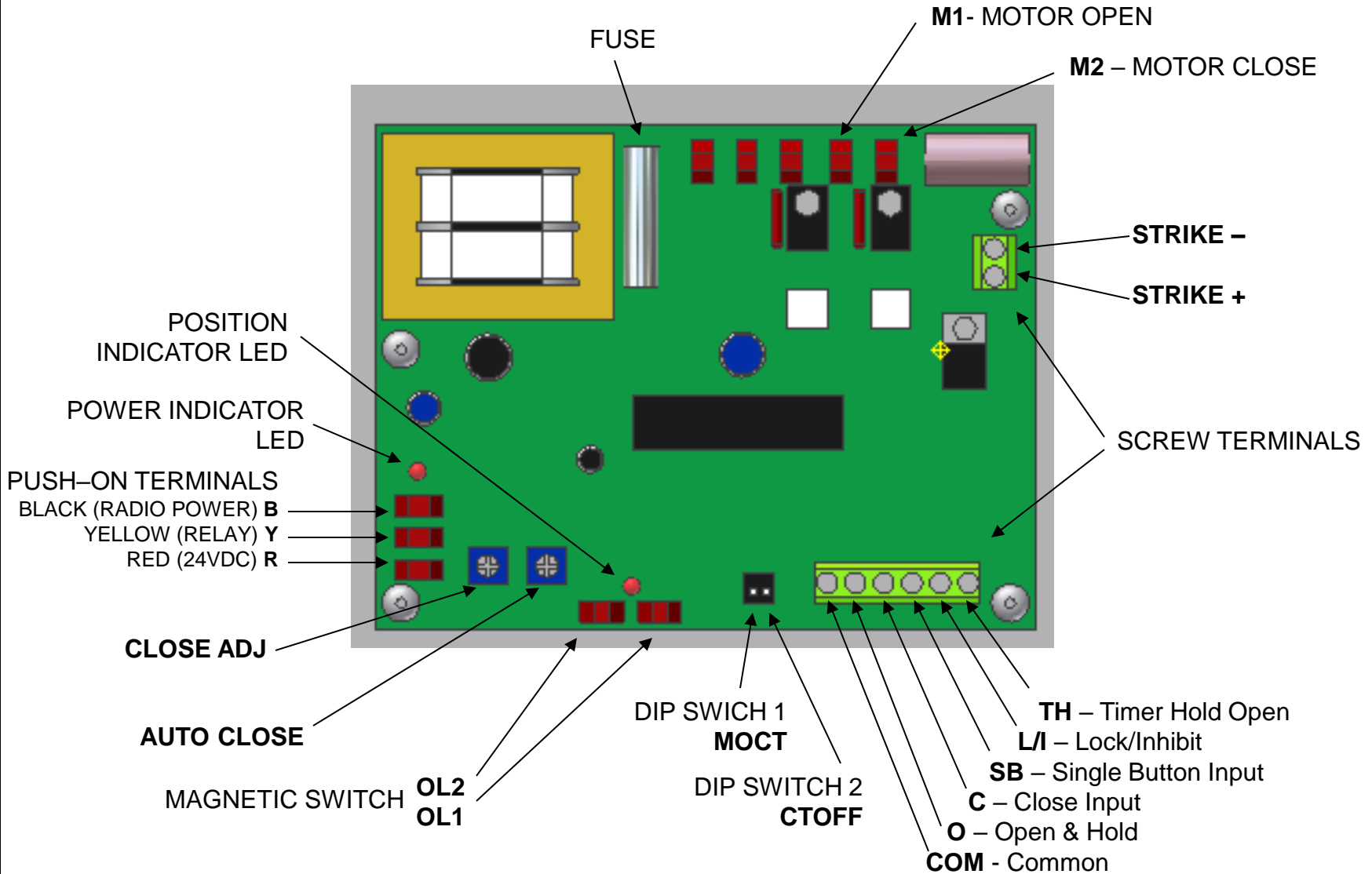



## MAIN CIRCUIT BOARD FEATURE DESCRIPTIONS

TERMINAL	FUNCTION	DESCRIPTION
<b>COM</b>	COMMON	INPUT WIRING "COMMON" CONNECTION
<b>O</b>	OPEN & HOLD	ON MOMENTARY SIGNAL IT WILL CAUSE AN OPENING, OR A STOP AND REVERSE IF CLOSING. <i>DOOR WILL TIMEOUT AND CLOSE IF DIP SWITCH 2 IS "OFF". IF ACTIVATED AND MAINTAINED, DOOR WILL STAY OPEN.</i>
<b>C</b>	CLOSE INPUT	N/A
<b>SB</b>	SINGLE BUTTON INPUT	DUPLICATES RADIO INPUT. THE FOLLOWING IS THE SAME FOR RADIO INPUT – A SIGNAL WILL ALWAYS CAUSE AN OPENING EXCEPT AT THE FULLY OPEN POSITION.
<b>L/T</b>	LOCK/INHIBIT	WHEN ACTIVATED THE DOOR WILL EMERGENCY STOP AND REMAIN STOPPED UNTIL SIGNAL IS REMOVED. IF THE DOOR IS AT REST, EITHER OPEN OR CLOSED, IT WILL NOT ACCEPT A SIGNAL AS LONG AS SL IS ACTIVATED. IF L/I IS ACTIVATED WHILE OPENING, THE DOOR WILL STOP. IF THE CLOSE TIMER (DIP SWITCH 2) IS "OFF", AND L/I IS RELEASED, THE TIMER WILL TIME OUT AND THE DOOR WILL CLOSE. IF L/I IS ACTIVATED DURING A CLOSING CYCLE, THE DOOR WILL STOP AND AWAIT ANOTHER SIGNAL. THIS WILL MEET THE CONDITIONS OF A SAFETY MAT CONDITION.
<b>TH</b>	TIMER HOLD OPEN	IF MAINTAINED IT WILL PREVENT AUTOMATIC CLOSE. IF THERE IS A MOMENTARY CONTACT IT WILL RESET THE CLOSE TIMER AND THE TIMER WILL BEGIN TIMING WHEN CONTACT IS RELEASED. THIS COULD BE USED WITH A SAFETY MAT APPLICATION WHERE THE ONLY CONCERN IS ON THE CLOSING CYCLE AS IT DOES NOT PREVENT AN OPENING.

**MAIN CIRCUIT BOARD**  
FEATURE DESCRIPTIONS

<b>TERMINAL</b>	<b>FUNCTION</b>	<b>DESCRIPTION</b>
<b>MOCT Dip Switch #1</b>	<b>MANUALLY OPEN CLOSE TIMER</b>	WHEN SWITCH IS "ON" AND DOOR IS OPENED MANUALLY TO FULL OPEN, DOOR WILL TIME OUT AND MANUALLY CLOSE. WHEN SWITCH IS "OFF" AND THE DOOR IS OPENED TO FULL OPEN, IT WILL STAY OPEN UNTIL A NEW SIGNAL IS RECEIVED.
<b>CTOFF Dip Switch #2</b>	<b>CLOSE TIMER OFF</b>	WHEN SWITCH IS SET TO "ON" IT WILL INHIBIT THE CLOSE TIMER AND THE DOOR WILL REMAIN OPEN UNTIL A SIGNAL BUTTON, RADIO OR CLOSE INPUT IS RECEIVED.
<b>CLOSE ADJ</b>	<b>ADJUST MOTOR ACTIVATION TIME WHEN CLOSING DOOR</b>	TURN CLOCKWISE TO INCREASE TIME THAT THE MOTOR IS ACTIVATED WHEN CLOSING THE DOOR. TURN COUNTER-CLOCKWISE TO DECREASE TIME THAT THE MOTOR IS ACTIVATED WHEN CLOSING THE DOOR. <i>ONLY SMALL FRACTIONS OF A ROTATION ARE REQUIRED TO ADJUST THE TIME.</i>
<b>AUTO CLOSE</b>	<b>ADJUST DWELL TIME OF DOOR IN OPEN POSITION</b>	TURN CLOCKWISE TO INCREASE THE TIME THE DOOR REMAINS OPEN. TURN COUNTER CLOCKWISE TO DECREASE THE TIME THE DOOR REMAINS OPEN. <i>ONLY SMALL FRACTIONS OF A ROTATION ARE REQUIRED TO ADJUST THE TIME.</i>
<b>POWER INDICATOR LED</b>	<b>INDICATES POWER ATTACHED</b>	LED IS ON WHEN POWER IS ATTACHED TO UNIT. LED IS OFF WHEN NO POWER IS GOING TO THE UNIT.
<b>POSITION INDICATOR LED</b>	<b>INDICATES LOCATION OF DOOR</b>	LED REMAINS ON UNTIL THE MAGNETIC SWITCH IS ACTIVATED.

## TROUBLESHOOTING

ISSUE	CAUSE	SOLUTION
DOOR DOES NOT OPEN	MOTOR ROTATION CONFIGURATION IS INCORRECT	REFER TO <b>CHANGING HAND</b> ON PAGE 15
	STRIKE PLATE DOES NOT ACTIVATE	VERIFY STRIKE IS INSTALLED CORRECTLY BY REFERRING TO MANUFACTURERS INSTRUCTIONS.
DOOR DOES NOT OPEN WIDE ENOUGH	IMPROPER LEVER ARM INSTALLATION	REFER TO <b>LEVER ARM ADJUSTMENT</b> ON PAGE 7
	IMPROPER PLACEMENT OF MAGNET/SENSOR	REFER TO <b>LEVER ARM ADJUSTMENT</b> (PAGE 7) AND <b>OPENING ANGLE</b> (PAGE 14)
DOOR DOES NOT STAY OPEN LONG ENOUGH	INCORRECT SETTING	REFER TO <b>OPEN DWELL TIME</b> (PAGE 13)
DOOR DOES NOT SHUT	INCORRECT SETTING FOR MOTOR ACTIVATION TIME	REFER TO <b>CLOSING ACTIVATION TIME</b> (PAGE 13)
	INCORRECT SETTING OF STRIKE	REFER TO <b>ELECTRIC STRIKE INSTALLATION</b> (PAGES 8 AND 9)
	OBSTRUCTION, WEATHER STRIPPING	PLUMB AND SQUARE THE DOOR. REPLACE WARPED DOOR. CLEAR DOOR JAMB OR DOOR STOP OBSTRUCTION. STIFF OR THICK WEATHER STRIPPING MAY NEED TO BE REMOVED.
	DIP SWITCH SETTINGS WRONG	ALIGN DIP SWITCH SETTINGS (PAGE 11)
DOOR DOES NOT LATCH / DOOR DOES NOT OPEN	STRIKE IMPROPERLY ASSEMBLED/ALIGNED	REFERENCE <b>ELECTRIC STRIKE INSTALLATION</b> (PAGES 8 AND 9)
STRIKE WORKS INTERMITTENTLY	BAD SOLENOID	REPLACE STRIKE
NOTHING HAPPENS WHEN TRANSMITTER BUTTON IS PRESSED	TRANSMITTER SWITCHES DO NOT MATCH RECEIVER	SEE <b>PROGRAMMING THE RECEIVER</b> (PAGE 11)
	CONTROLLER BATTERY DEAD	REPLACE BATTERY IN TRANSMITTER
	BLOWN FUSE	REPLACE FUSE (1 AMP 250V)

## LEFT HAND DOOR

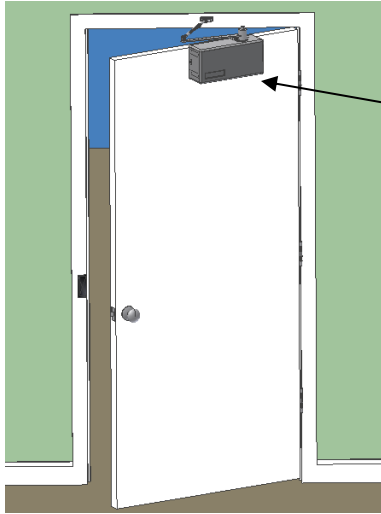

DOOR MOUNT (2300DL)

## POWER ACCESS MODEL 2300 CONFIGURATIONS

UNIT MOUNTED TO DOOR ON  
PULL SIDE OF DOOR

- PROVIDED WITH REGULAR FOREARM
- MOTOR SHAFT FACING UPWARD
- POWER CORD EXITS TOWARD HINGE SIDE OF UNIT

## RIGHT HAND DOOR

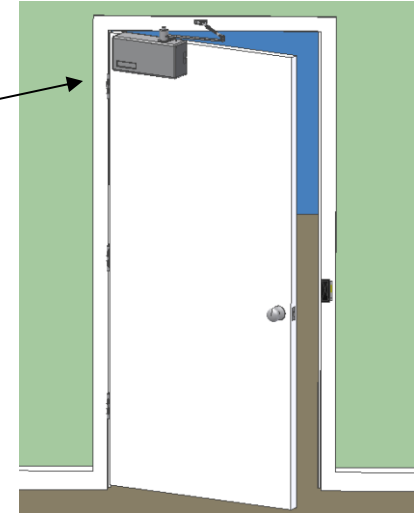

DOOR MOUNT (2300DR)

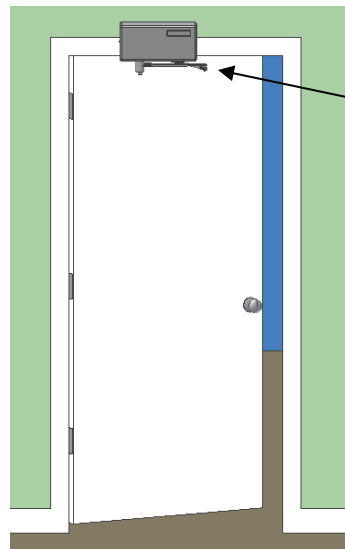

JAMB MOUNT (2300JL)

UNIT MOUNTED TO JAMB ON  
PUSH SIDE OF DOOR

- PROVIDED WITH EXTENDED FOREARM
- MOTOR SHAFT FACING DOWNWARD
- POWER CORD EXITS TOWARD HINGE SIDE OF UNIT

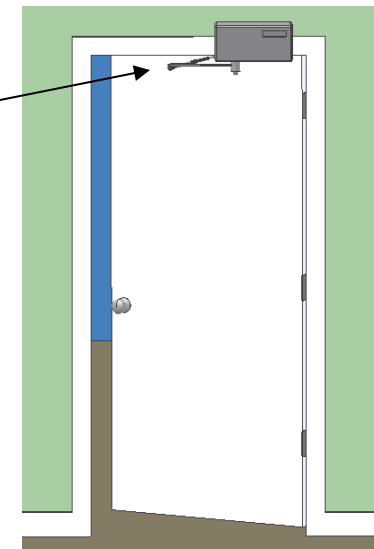

JAMB MOUNT (2300JR)